



УДК 902.904 (470.631-25)
МРНТИ 03.41.91

<https://doi.org/10.52967/akz2023.4.22.66.85>

The Dead among the Living at the Bronze Age Settlements in the Southern Urals: approaches to research and classification of intramural burials

©2023 Berseneva N.

Keywords: South Urals, Bronze Age, burials at the settlements, burial practice

Түйін сөздер: Оңтүстік Орал, қола дәуірі, қоныстарда жерлеу, жерлеу тәжірибесі

Ключевые слова: Южный Урал, бронзовый век, погребения на поселениях, погребальные практики

Natalia Berseneva¹

¹Doctor of Historical Sciences, Institute of History and Archaeology, Ural Branch of RAS, South-Ural State University, Chelyabinsk, Russia. E-mail: bersnatasha@mail.ru

This study concerns the Sintashta, Abashevo, Petrovka, Alakul and Srubnaya (Timber-grave) cultural groups that occupied the South Urals in the Bronze Age. These groups are currently dated from the 21st to the 15th centuries BC. The intramural human burials were often discovered at the settlements. Burials can be divided into three types. The first is the burials that were arranged in accordance to the common burial rules: flexed position, on the left side, sometimes with grave goods. The second type are human skeletons or burials that did not match the rules of proper mortuary treatment: dismembered, mutilated bodies in non-standard position. All of these burials belonged to adults, presumably males. The third type is represented by finds of separate human bones or parts of skeletons (both adults and sub-adults). Our investigation allowed us to conclude that children's burials in the early period (Sintashta-Abashevo, Petrovka) were a variant of the normal burial ritual; adult skeletons were represented in both types. In the next period (Srubnaya-Andronovo) the adult burials at the settlements were allowed by common burial practice as well as the children's. In both chronological periods, type 2 included mainly adult remains.

Source of funding: The publication was carried out within the framework of the state program «Priority 2030».

For citation: Berseneva, N. 2023. The Dead among the Living at the Bronze Age Settlements in the Southern Urals: approaches to research and classification of intramural burials. *Kazakhstan Archeology*, 4 (22), 66–85. DOI: [10.52967/akz2023.4.22.66.85](https://doi.org/10.52967/akz2023.4.22.66.85)

Наталья Александровна Берсенева¹

¹тарих ғылымдарының докторы,
Тарих және археология институты, РҒА Орал Бөлімі,
Оңтүстік Орал мемлекеттік университеті,
Челябинск, Ресей

Оңтүстік Оралдың қола дәуірі қоныстарындағы тірі адамдар жанындағы өлілер: зерттеу әдістері және тіршілік кеңістігіндегі жерлеуді жіктеу

Мақалада Оңтүстік Оралдағы (б.д.д. II мыңж. бірінші жартысы) қола дәуірінің қима, алакөл, петровск, абашевск, сынтасты мәдениеттері қоныстарындағы жерлеулер талданады. Жерлеулерді

Наталья Александровна Берсенева¹

¹доктор исторических наук, Институт истории и археологии, Уральское Отделение РАН, Южно-Уральский государственный университет, Челябинск, Россия

Мертвые рядом с живыми на поселениях бронзового века Южного Урала: подходы к исследованию и классификация интрамуральных погребений

В статье проанализированы погребения на поселениях синташтинской, абашевской, петровской, алаккульской и срубной культур бронзового века Южного Урала (первая половина II тыс. до н.э.). Захоронения



шамамен 3 түрге бөлуге болады. Бірінші түрі – барлық ережелерге сай орналасқан, тиісті жерлеу орындарында біз байқай алатын жерлеу: жанымен жатқызылған, қолдары бетінің алдына қойылған, ыдыс немесе басқа зат бар. Екінші түрі – нормативке сай жерленбеген адам мүрдесі – қаңқаның кейбір бөлшектерінің болмауы, жатқызылуы ережеге сай емес, жерлеу заттары жоқ. Үшінші түр – қоныстың мәдениет қабатынан алынған шашылған сүйектер. Жүргізілген зерттеулер бізге абаш-синташты кезеңінде қоныстардағы балалар жерлеуі жерлеу салтына сай жерленген нұсқасына, ал үлкен адамдардың жерлеуі көп емес және 1 және 2 түрге жатады деп қортындылауға мүмкіндік берді. Келесі қима-андроновтық кезеңде үлкен адамдар жерлеуі көбейген, олар да жерлеу дәстүрінің нормасына сай нұсқада. Жалпы, екі хронологиялық кезең үшін де үлкен адамдар қалдықтары негізінен 2 түрде болды.

Қаржыландыру көзі: Мақала «Приоритет 2030» мемлекеттік бағдарлама аясында даярланды.

Сілтеме жасау үшін: Берсенева Н.А. Оңтүстік Оралдың қола дәуірі қоныстарындағы тірі адамдар жанындағы өлілер: зерттеу әдістері және тіршілік кеңістігіндегі жерлеуді жіктеу. *Қазақстан археологиясы*. 2023. № 4 (22). 66–85-бб. (Ағылшынша). DOI: [10.52967/akz2023.4.22.66.85](https://doi.org/10.52967/akz2023.4.22.66.85)

можно условно разделить на три типа. Первый тип – погребения, устроенные в соответствии с правилами, которые мы можем наблюдать на соответствующих могильниках: на боку, руки сложены перед лицом, присутствует сосуд или иной инвентарь. Второй тип – человеческие останки, не получившие нормативного погребения – отсутствие частей скелета, нестандартная позиция, отсутствие погребального инвентаря. Третий тип – разрозненные кости, полученные из культурного слоя поселений. Проведенное исследование позволило нам заключить, что в абашево-синташтинский период, детские погребения на поселениях были вариантом нормативного погребального обряда, взрослые останки немногочисленны и представлены в типах 1 и 2. В следующий, срубно-андроновский период, количество взрослых погребений возрастает, они также становятся вариантом нормативного погребального обряда. В целом, в типе 2 представлены в основном взрослые останки для обоих хронологических периодов.

Источник финансирования: Статья подготовлена в рамках государственной программы «Приоритет 2030».

Для цитирования: Берсенева Н.А. Мертвые рядом с живыми на поселениях бронзового века Южного Урала: подходы к исследованию и классификация интрамуральных погребений. *Археология Казахстана*. 2023. № 4 (22) (на англ. яз.). С. 66–85. DOI: [10.52967/akz2023.4.22.66.85](https://doi.org/10.52967/akz2023.4.22.66.85)

Introduction

The custom of burying people inside dwellings, either habitable or abandoned, was practiced in many ancient societies. In fact, this is one of the earliest known burial practices, believed to have marked the transition to sedentary life and a food producing economy [Antonova 1990: 38]. Its earliest instances were recorded in the Late Mesolithic and early farming villages in the Near East [Ibid.: 38; Scott 1999: 95]. While intramural burials of adults mostly date to the Mesolithic and Neolithic, those of children were common in later societies as well, including state societies.

An important and complicated question, widely discussed in modern archaeology is should we consider the settlement burials as “ordinary” or “normative” for different cultures and periods or we should not? What were the reasons for such burial practices?

This paper has two purposes. The first is to investigate the Sintashta, Petrovka, Alakul’ and Srubnaya settlement burials in terms of “deviant” or normative burial ritual¹. The second is to try to define the possible determinants of such a type of burial activity and to explore if the settlement burials in the Urals were a part of “normative” burial ritual or if they were not.

This study concerns the South Urals in the Bronze Age of the presumably Sintashta, Petrovka, Alakul’ and Srubnaya cultural groups. They are currently dated from the 21st to the 15th centuries cal BC [Molodin et al. 2014]. The sites are located in the steppe part of the Southern Urals. The Ural area can

¹ According to E. Aspöck, “deviant burials” are those that are different from the normative burial ritual of the respective period, region or cemetery” [Aspöck 2008].



be defined in terms of its geographic location as a natural boundary between Europe and Asia. In terms of administrative divisions, this area covers several provinces of the Russian Federation: Bashkortostan, Orenburg, Chelyabinsk, and Kurgan regions as well as the northwestern part of Kazakhstan. It is characterized by a great expansive landscape and environmental diversity: steppe, forest-steppe, forests, and mountains. The beginning of the Bronze Age in the steppe and the southern forest-steppe was marked by the emergence of food-producing economies. This was based primarily on livestock breeding, which periodically changed its form over a period of almost two thousand years.

Settlements and formal cemeteries, presumably kurgans, represent the sites very well. Nevertheless, the mortuary practices included the burials at the settlements as well. So far, burials have been discovered at 40 Bronze Age settlements in the South Ural region at minimum. Such a form of the disposal of the dead appeared in the region in the Abashevo-Sintashta time period (21st–18th centuries cal. BC). The tradition continued during the next, Srubnaya-Alakul' period (18th–15th centuries cal. BC)² (fig. 1).

Settlements

Sintashta Culture

Permanent settlements, which are round or oval in plan, are supported by sophisticated systems of fortification; the internal space has a very structured organization and is almost entirely occupied by standard buildings that are organized into regular blocks. The total area of the settlements ranges from 0.8 to 2.0 hectares. The diagnostic feature of the Sintashta settlements is a closed fortification that consisted of a ditch, surrounded by a fence or wall. This feature is based upon either the round or rectangular plan. The number of houses, which are usually rectangular or trapezoidal, correlates with the size of a settlement. The house sizes are very similar, usually between 100 and 250 m². The houses are usually found on foundations dug 20–30 cm into the natural rock; postholes, wall ruins, and some other features relating to the interior are also found. The construction principles are standard: a frame-pillar construction was used exclusively. Building material consisted mostly of soil and wood. The long longitudinal walls were adjacent to the next house. Every house contains one or several wells [for more details see: Koryakova, Epimakhov 2007].

Petrovka Culture

About a dozen settlements, occupying up to 3.5 hectares, with rectangular fortifications are currently well described. They are located in similar topographic conditions taking up flat river or (rarely) lake terraces. Unlike the Sintashta sites, the Petrovka settlements have a linear street layout. Some of the Petrovka fortified settlements were established over the Sintashta settlements. Fortifications vary greatly. For example, in the Kulevchy site the fortification was practically symbolic being represented only by a simple enclosure. A full-scale defensive system, as at the Usty'e settlement, consists of a wood and earthen wall with a ditch. The aboveground and mainly rectangular houses at the Petrovka settlements were of a frame-pillar construction and were adjacent to the defensive wall as at the Sintashta sites. They are usually of a standard size within a settlement but vary in general between 80 and 160 m². Entrances were in the corner of the house and fronted on the street that separates two blocks. Each house had a well and an oven [for more details see: Koryakova, Epimakhov 2007].

² We adhere to the Bronze Age periodization of the South Urals, proposed by A.V. Epimakhov [Epimakhov 2010].

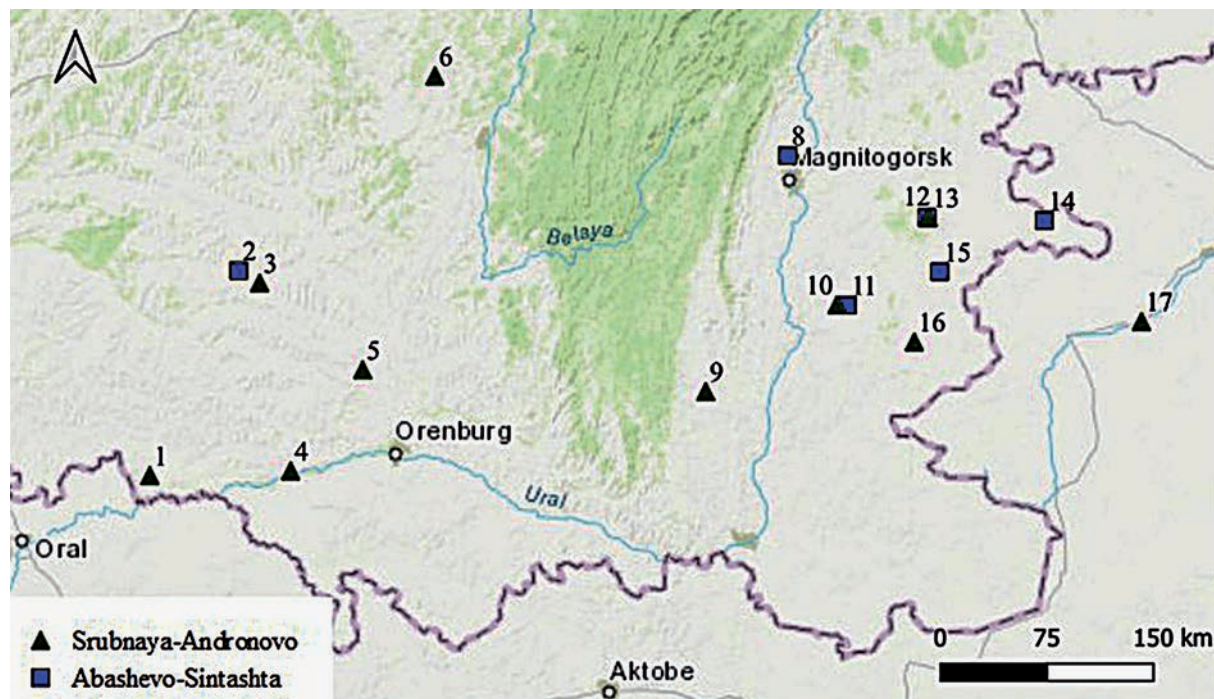

Fig. 1. Map of key Bronze Age settlements with human burials: 1 – Kuzminkovskoe II; 2 – Maloyuldashevo; 3 – Tokskoe; 4 – Rodnikovoe; 5 – Gornyi; 6 – Muradymovo; 7 – Korkino I; 8 – Malo-Kizil'skoe; 9 – Tanalyk; 10 – Lis'yi Gory I; 11 – Arkaim; 12 – Ust'e I; 13 – Ust'e III; 14 – Kulevchi III; 15 – Kamennyi Ambar; 16 – Mirnyi IV; 17 – Lisakovskoe I

1-сур. Жерлеу орны табылған қола дәуірінің маңызды қоныстарының орналасу картасы: 1 – Кузьминков II; 2 – Малоюлдашево; 3 – Ток; 4 – Родниковое; 5 – Горный селосы; 6 – Мурадымово; 7 – Коркино I; 8 – Мало-Кизыл; 9 – Таналык; 10 – Лисьи Горы I; 11 – Аркаим; 12 – Устье I; 13 – Устье III; 14 – Кулевчи III; 15 – Каменный Амбар; 16 – Мирный IV; 17 – Лисаков I

Рис. 1. Карта расположения ключевых поселений эпохи бронзы, на которых обнаружены захоронения: 1 – Кузьминковское II; 2 – Малоюлдашево; 3 – Токское; 4 – Родниковое; 5 – селище Горный; 6 – Мурадымово; 7 – Коркино I; 8 – Мало-Кизильское; 9 – Таналык; 10 – Лисьи Горы I; 11 – Аркаим; 12 – Устье I; 13 – Устье III; 14 – Кулевчи III; 15 – Каменный Амбар; 16 – Мирный IV; 17 – Лисаковское I

Srubnaya Culture

The settlements vary in size, but large settlements (occupying more than 10,000 m²) are not numerous. The settlements usually occupy either the terraces of small rivers or the main terraces. Judging by the difference in size (from 15 to 200 m²), rectangular and square houses differed not only in construction but also in function. Houses were built from wood and ground but some house basements were faced with stone. These houses were fairly substantial. They were semisubterranean constructions, with basements 0.5–1.2 m, with vertical pillar frames. Other houses were built above ground but with a similar pillar frame construction. The houses usually had only one entrance. Open fireplaces, storage pits, and wells are found within the houses [for more details see: Koryakova, Epimakhov 2007].



Alakul Culture

The settlements are located on the first river terraces or in the low lake banks, usually very close to a large valley. The general settlement surface does not exceed 10,000 m². The planning structure of settlements is predominantly linear; the houses are organized into one row or, rarely, into two rows running along the riverbank. The Alakul houses are rectangular, measuring 140–270 m² in surface, dug into the ground 0.5–0.7 m. The entrances were designed as entryways in a corner or in the wall. The numerous postholes (up to three hundred) on a floor give evidence to the postframe construction of a building. The roofs are thought to be two slopes. Typical elements of Alakul interiors were wells, storage pits, and fireplaces, the number of which can reach five to seven in a single house [see: Koryakova, Epimakhov 2007].

Abashevo-Sintashta period

Children's burials. “The majority of individuals buried in settlements during this period were infants up to two years old. Adult burials were discovered at only two settlements. Children's interments under the floors of dwellings were found at the Kamennyi Ambar (fig. 2), Arkaim, Ustye, and Kulevchi III settlements (fig. 3) [Vinogradov 1982; Alaeva 1998; Koryakova et al. 2011; Kupriyanova 2018]. They were located near the entrance or walls of structures at Arkaim, Ustye, and Kulevchi III, in the center of the dwelling beside the well at Kamennyi Ambar, and inside the well at Arkaim.

Therefore, we have at least 10 Sintashta and Petrovka child burials, but of the Sintashta burials there is only one – the grave at Kamennyi Ambar. It had a significant depth from the floor level of the dwelling – 70 cm, a wooden construction, which could possibly have been meant as a ceiling. The grave goods consisted of a Sintashta vessel and sacrificial deposit – the head and extremities of sheep. The grave was located in the center of the dwelling near the well [Koryakova et al. 2011].

Burials from dwellings 2 and 6 of the inner circle of the Arkaim settlement (baby burials arranged in special pits) also belong to the early period. The grave in building 2 (pit 4) was located near the wall and was relatively deep, 50 cm below the floor level. The deceased was laid in a standard position on the left side in a contracted position and hands near the face, head to the north. A vessel of the Sintashta type was placed near the head [Zdanovich G., Malyutina, Zdanovich D. 2020: 261, fig. 3.2.1; 3.2.5; 3.2.6]. The second burial was found in dwelling 6 (pit 4). The child was also placed in usual position, with his head to the southwest, and was accompanied by a ceramic vessel of the Petrovka type [Zdanovich G., Malyutina, Zdanovich D. 2020: 304, fig. 3.6.1; 3.6.11; 3.6.12–1]. The ritual of infant burials at Arkaim was generally similar to the intramural burials of the Petrovka culture at the settlement of Ustye I [Vinogradov, Berseneva 2013: fig. 5; 6]. In addition, at the Arkaim settlement, human remains were found in the well (dwellings 1–6, pit 1). G.B. Zdanovich and his co-authors believe that two of the deceased. The bones were represented by fragments. The second buried (a teenager, as the authors of the publication believe) lay on his left side in a severely crouched position and was partially covered with a large stone slab. The remains were located in the middle part of the filling of the well, artifacts firmly associated with them have not been found [Zdanovich G., Malyutina, Zdanovich D. 2020: 298–301, fig. 3.6.9].

In contrast to the Sintashta grave, the Petrovka pits were quite small in their sizes and depth (usually 20–30 cm, 50 cm maximum) and included only pottery. Their location was rather different – near entrances, walls, or corners of the dwellings [Vinogradov and Berseneva 2013]. It is necessary to note that the “settlement” burial rite corresponded in general with the ordinary cemetery rite, including the placement of pottery and in the Sintashta case, the sacrificial deposit.

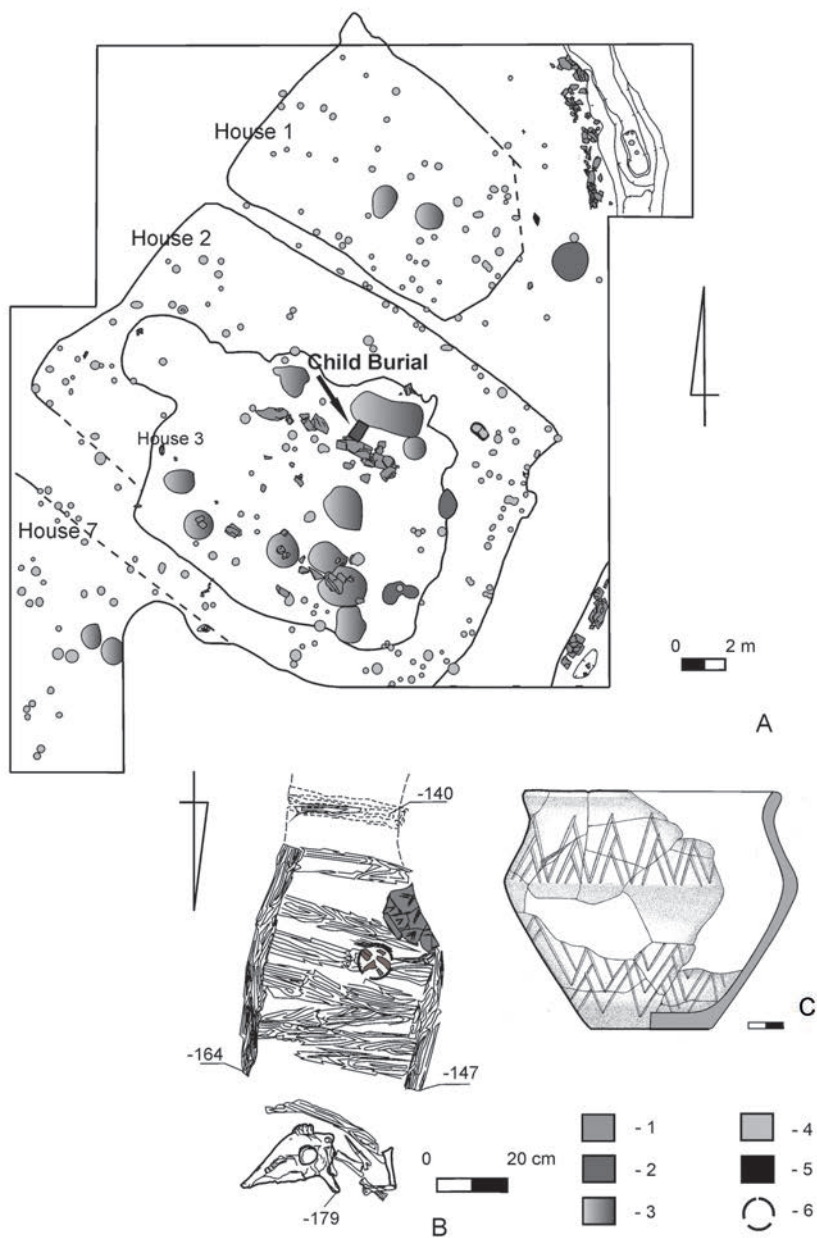

Fig. 2. Plans of the fortified settlement Kamenny Ambar (A), child's burial in building 2 (B), ceramic vessel (C).
Symbols: 1 – stones; 2 – large pits; 3 – wells; 4 – location of children's bones in the burial,
after – Vinogradov, Berseneva 2013: fig. 2

2-сур. Каменный Амбар бекіністі қонысы (A); құрылыстағы бала жерлеуі (B); керамика ыдыс (C).
Шартты белгілер: 1 – тастар; 2 – үлкен шұңқырлар; 3 – құдықтар;
4 – жерлеудегі бала сүйектерінің орналасуы ([Vinogradov, Berseneva 2013: fig. 2] бойынша)
Рис. 2. Укрепленное поселение Каменный Амбар (A); детское погребение в постройке 2 (B);
керамический сосуд (C). Условные обозначения: 1 – камни; 2 – большие ямы; 3 – колодцы;
4 – местонахождение детских костей (по: [Vinogradov, Berseneva 2013: fig. 2])

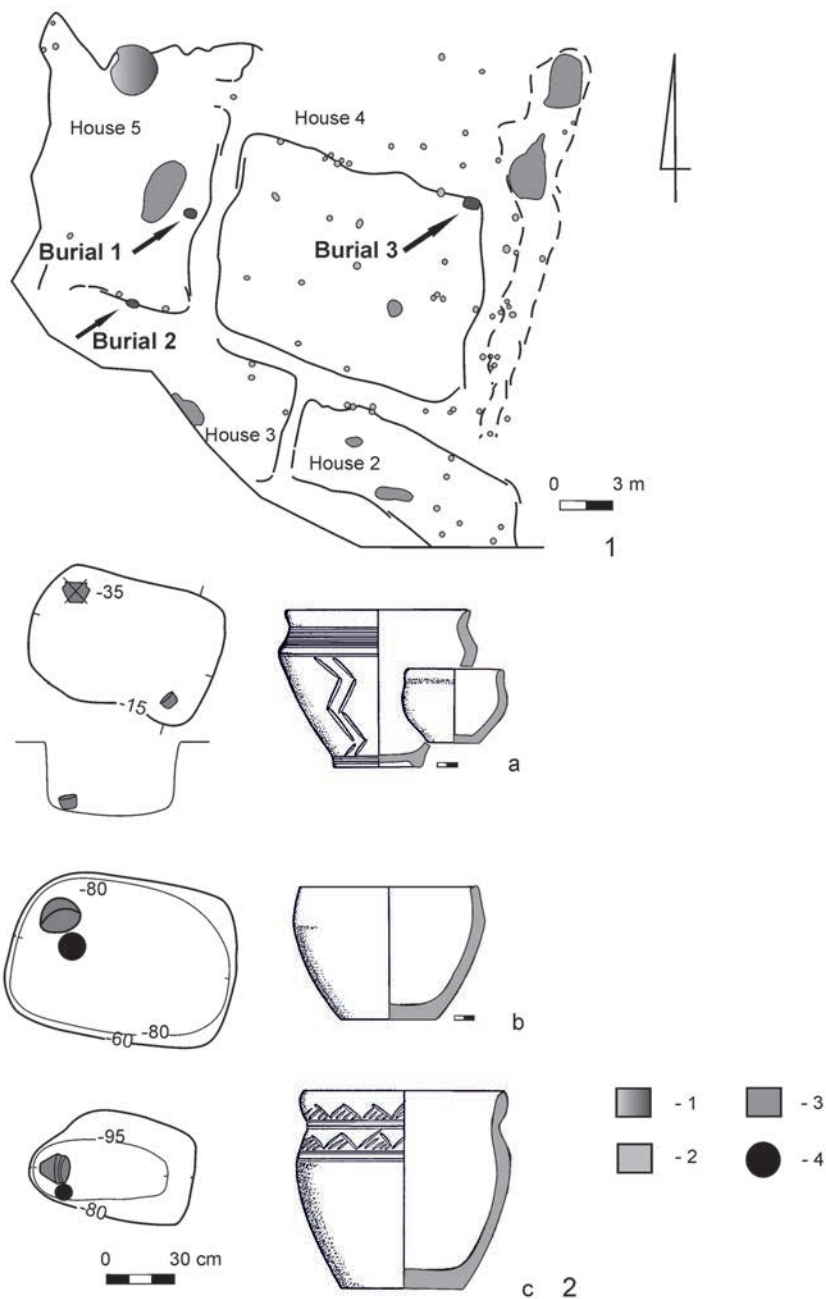

Fig. 3. Kulevchi III settlement (a), children's burials in dwellings 4 (b) and 5 (c), ceramic vessels.
 Symbols: 1 – well; 2 – post holes; 3 – large pits; 4 – location of children's bones in the burials,
 after – Vinogradov, Berseneva 2013: fig. 6

3-сур. Кулевчи III қонысы (а), тұрғын үйдегі баланың жерлеуі 4 (b) және 5 (c), керамика ыдыстар.

Шартты белгілер: 1 – құдық; 2 – тұғыр ойықтары; 3 – үлкен шұңқылар;

4 – жерлеудегі бала сүйектерінің орналасуы ([Vinogradov, Berseneva 2013: fig. 6] бойынша)

Рис. 3. Поселение Кулевчи III (а), детские погребения в жилищах 4 (b) и 5 (c), керамические сосуды.

Условные обозначения: 1 – колодец; 2 – столбовые ямки; 3 – большие ямы;

4 – местонахождения детских костей (по: [Vinogradov, Berseneva 2013: fig. 6])



Unfortunately, anthropological age identification was not conducted for all the remains. In the shallow pits at the Kulevchi III settlement there were no bones, only dust from skull bones and, in one case, the bones did not preserve at all. It is possible that the buried were newborn babies. The same situation with bones, despite the significant depth of the pit, was discovered at the Kamennyi Ambar settlement. In the Ustye burials, two of children were 1 year of age at death, one was a newborn and bones of the others were totally decayed. Thus, we may conclude that children up to 1 year were buried at the Sintashta and Petrovka settlements.

Adult burials

Not so long ago, we were unable to discuss the adult burials at the Sintashta and Petrovka settlements, because there were none. However, a few years ago, a grave of the Sintashta period was discovered at the Maloyuldashevo settlement in the Western Orenburg region [Morgunova et al. 2015]. The excavation yielded a great deal of material, from the Neolithic to the Late Bronze Age but the dwellings belonged to the Srubnaya period. The interment of three adult individuals (dating to the Sintashta period) was found outside the stone walls of the Srubnaya dwelling (see: Faizullin this volume). The pit was very shallow and it was not dug into the sterile soil. A middle-age male was placed in a contracted position on his right side. A ceramic vessel accompanied him along with a bronze awl and a cow bone. Near the feet of the first skeleton were the remains of a younger male (30–40 years old) placed in a heap along with leg bones from 5 sheep. Behind the middle-aged male was a young female in supine position. Her skull had traces of injury from a pointed-edged weapon. The female was accompanied with a great number of grave goods. A sacrificial deposit was arranged near the feet of the dead woman and included 5 sheep skulls.

We agree with the authors of the excavation that this complex is non-typical in every respect.

Firstly, chronological correlation of the burial and the dwelling is unclear. Was the burial arranged earlier than the dwelling or were they relatively simultaneous? If the latter case, the presence of the strange burial complex in the Srubnaya living space looks very unusual, indeed.

Secondly, despite the variability of the Sintashta mortuary practice, this burial broke the firm tradition of male burials on the left side only. The supine position of the female skeleton is also non-standard.

Thirdly, it is important to note that this was the first time anthropologists had found such fatal traumas on Sintashta skeletons.

The remains of the second male, as well as the animal bones, were probably a specific sacrificial complex, which we can clearly see in the plan of the grave.

How can we interpret this burial type? It is possible that there was no opportunity to bury the dead in the formal cemetery. For example, it may have been too far from the place of death. It might be they were intentionally buried outside the clan cemetery because of “wrong” or “dangerous” circumstance of the death. These people might have been victims of a war attack or crime, or death penalty.

It is hard to interpret the remains of individual 3. We can suppose that it could be a human sacrifice or the remains of an outlaw, a criminal or an enemy (stranger), which was a part of the sacrificial deposit along with the sheep bones.

The second important source for this period was the burials at the Malo-Kizilskoe settlement (fig. 4; 5). It was an Abashevo settlement, and unfortunately, it had been seriously damaged and almost destroyed long before the first excavation in 1948 [Salnikov 1954: 67–81; 1967: 35–38]. There were two excavation trenches at the settlement; human remains were discovered in both. The burned human skeleton

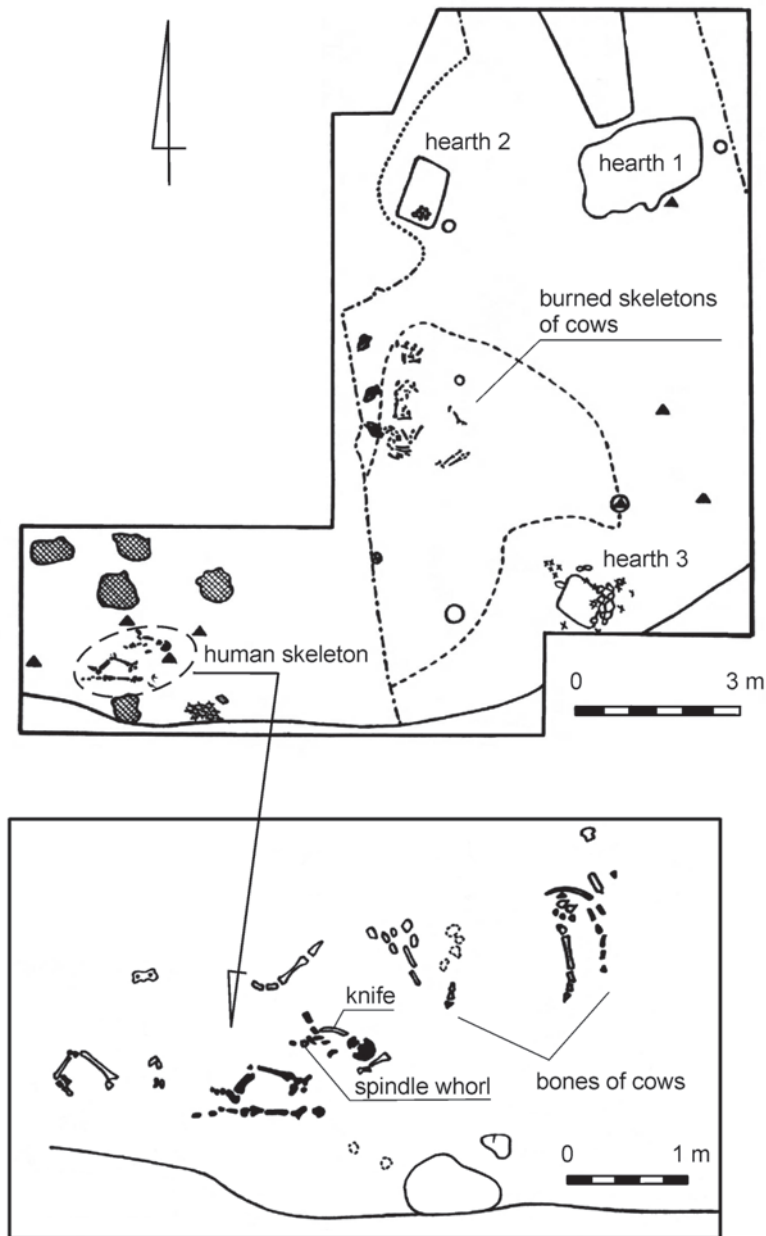

Fig. 4. Malo-Kizil'skoe settlement. Trench I. Human burial, after – Salnikov 1954: fig. 15, redrawn by Natalia Berseneva
4-сур. Мало-Кизыл қонысы. I арық. Адамның жерлеуі ([Сальников 1954: рис. 15] бойынша, Н.А. Берсеневаның сандық өңдеуі)
Рис. 4. Мало-Кизильское поселение. Траншея I. Погребение человека (по: [Сальников 1954: рис. 15], цифровая обработка Н.А. Берсеневой)

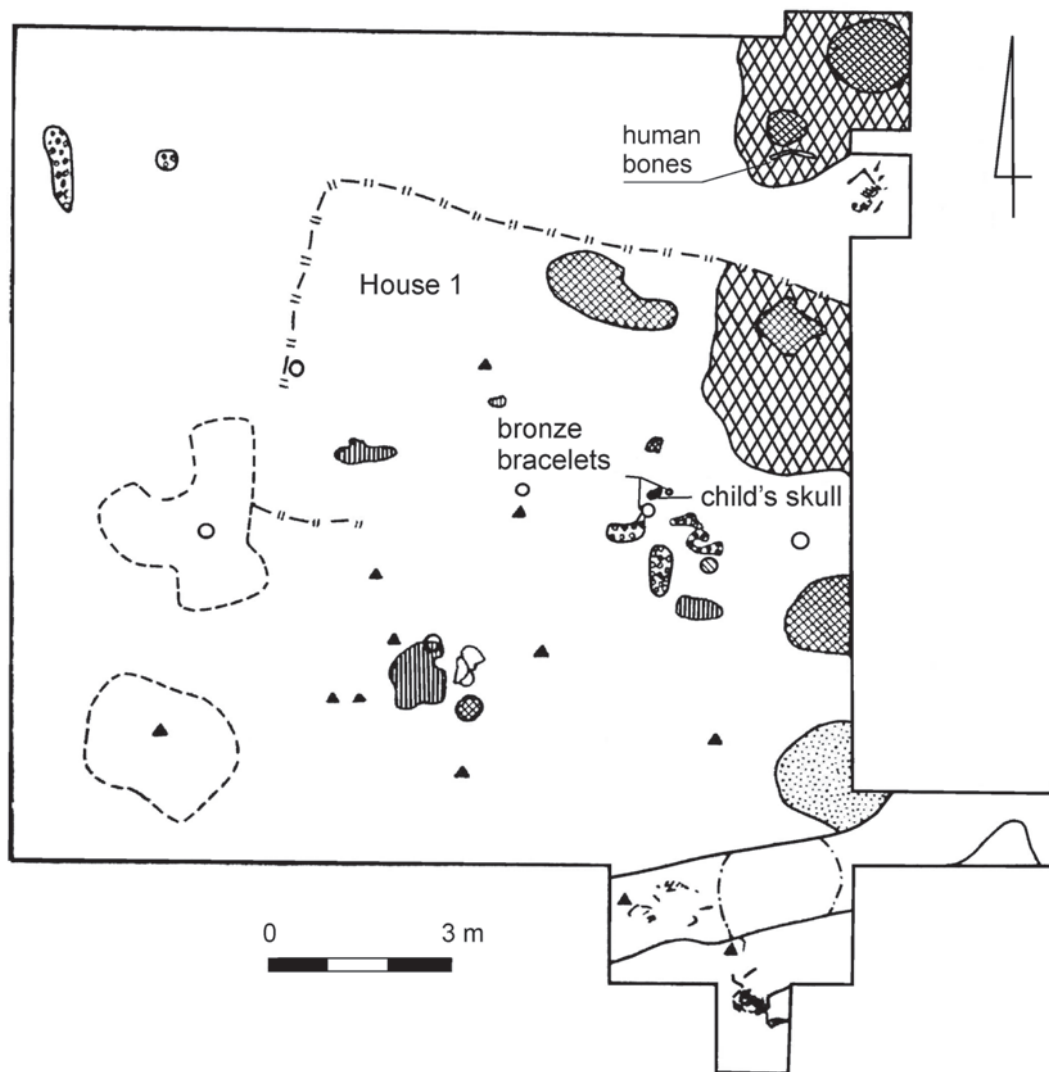

Fig. 5. Malo-Kizilskoe settlement. Trench III. Child burial, after – Salnikov 1954: fig. 18, redrawn by Natalia Berseneva
 5-сур. Мало-Кизыл қонысы. III арық. Баланың жерлеуі ([Сальников 1954: рис. 18] бойынша, Н.А. Берсеневаның сандық өңдеуі)
 Рис. 5. Мало-Кизыльское поселение. Траншея III. Погребение ребенка (по: [Сальников 1954: рис. 18], цифровая обработка Н.А. Берсеневой)



was found in the first excavation area. It laid on the ancient surface, on its back, with one leg in an unnatural position (fig. 3). Dwellings were not discovered. Cultural soil in this trench included a considerable amount of burned material.

In the second trench, the child burial (a cremation) was found in the dwelling, under the floor level (fig. 4). Among the remains, silver pendants and a bronze bracelet were discovered. Outside the dwelling, on the ancient soil level the “incomplete human skeleton” laid in a prone position. Its arm bones were not articulated, and the leg bones and skull were absent. A bronze bracelet and silver pendant were found near the skeleton.

The author of the excavation (K. Salnikov) considered the first burial “a result of the ritual activity” [Salnikov 1954: 73], and the third (female?) as displaying “traces of violent death and ancient dismemberment of the corpse” [Salnikov 1967: 38].

The Malo-Kizilskoe materials are a very important source for the Ural Bronze Age. Despite the fact that excavated areas are too small for firm conclusions, it looks like the only example of an Abashevo settlement that was destroyed as a result of possible war attack and the following fire resulting in a significant amount of burnt material in the soil.

However, the child burial in the dwelling had been clearly deliberate and was arranged before the settlement was destroyed—it was under the floor and the ornaments were intact. We should note that human burials have not been found at the Abashevo settlements in the Urals, let alone cremations. The Malo-Kizilskoe settlement is a unique example of an Abashevo settlement, which could have been destroyed as a result of war activity. Also it demonstrated that the child burial was arranged in accordance to the unusual rite for the Abashevo population, that is cremation.

We can conclude that in the Abashevo-Sintashta period, children’s burials in the living space were a type of the normal burial practice. They were arranged according to general rules and their only distinction from interments in the cemeteries was their placement at the settlements.

Adult burials cannot be interpreted in the same way. We have only two in the entire period discussed above; both of them were non-standard. Adult burials at the Malo-Kizilskoe settlement look accidental, the position and context evidence indicates that these people were not buried in accordance to the common rules and in the proper place – they were left wherever death overtook them. The burial at the Maloyuldashevo settlement was clearly deliberate and arranged according to most of the rules, however, the placement of the grave, the absence of the grave pit, the position of skeleton 3, and injuries on the female skull all indicate that some unusual events occurred resulting in this burial complex.

Thus, adult burials in the settlements of the Abashevo-Sintashta period could be classified as “deviant” – they do not fit into the model of the burial rite of the societies under study.

Srubnaya-Andronovo period

Human burials in Late Bronze Age settlements in the South-Urals are quite usual. As opposed to most of the intramural burials in the Abashevo-Sintashta period, we find not only adult individuals but also infant burials as well.

Human burials were discovered in at least 40 settlements in the area under study. Some interments look clearly deliberate, and the dead were laid in the usual position – on the left side. Other skeletons are disarticulated or dumped without any burial treatment.

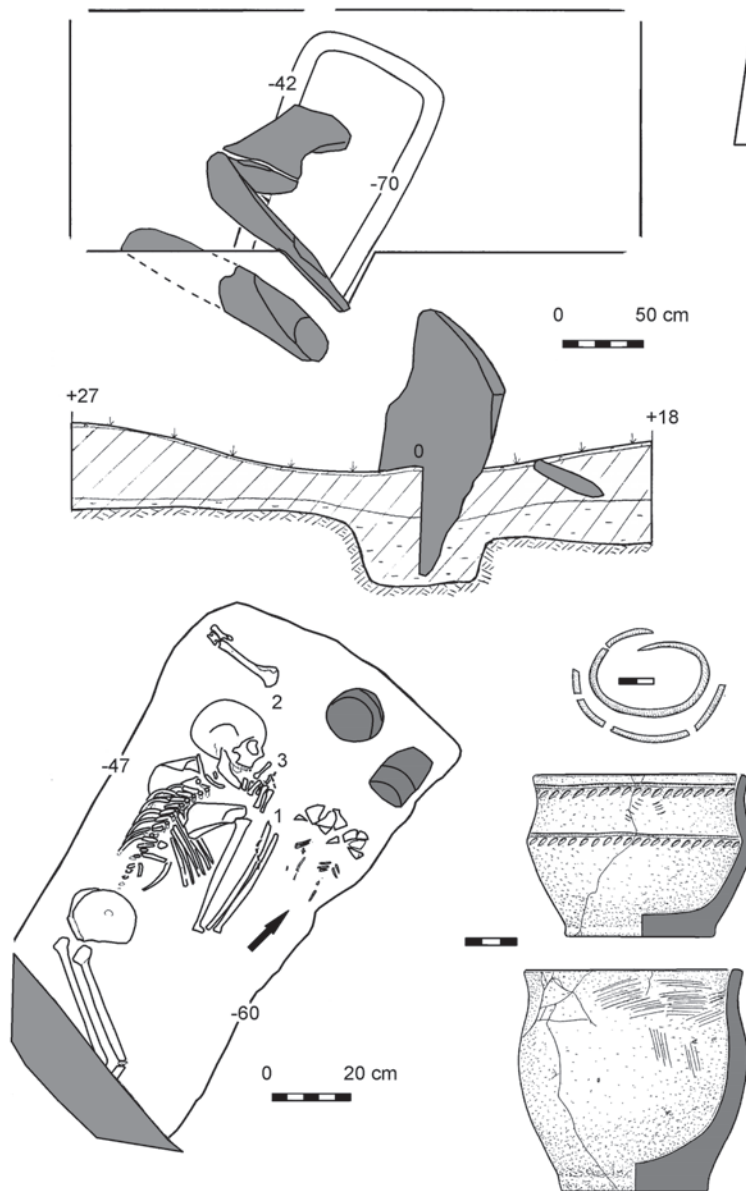

Fig. 6. Lisii Gory 1 settlement. Burial of a young woman (about 30 years old) and two newborn babies.

Grave goods: 1 – beads; 2 – animal bones; 3 – bronze bracelets and ceramic vessels,
after – Petrov, Kupriyanova 2016: Fig. 64–66

6-сур. Лисьи Горы 1 қонысы. Жас әйелдің (шамамен 30 жас) және екі жаңа туған сәбидің жерлеуі.

Инвентарь: 1 – моншақтар; 2 – жануар сүйектері; 3 – қола білезіктер және керамика ыдыстар
([Петров, Куприянова 2016: рис. 64–66] бойынша)

Рис. 6. Поселение Лисьи Горы 1. Погребение молодой женщины (около 30 лет) и двух новорожденных детей. Инвентарь: 1 – бусины; 2 – кости животных; 3 – бронзовые браслеты и керамические сосуды
(по: [Петров, Куприянова 2016: рис. 64–66])

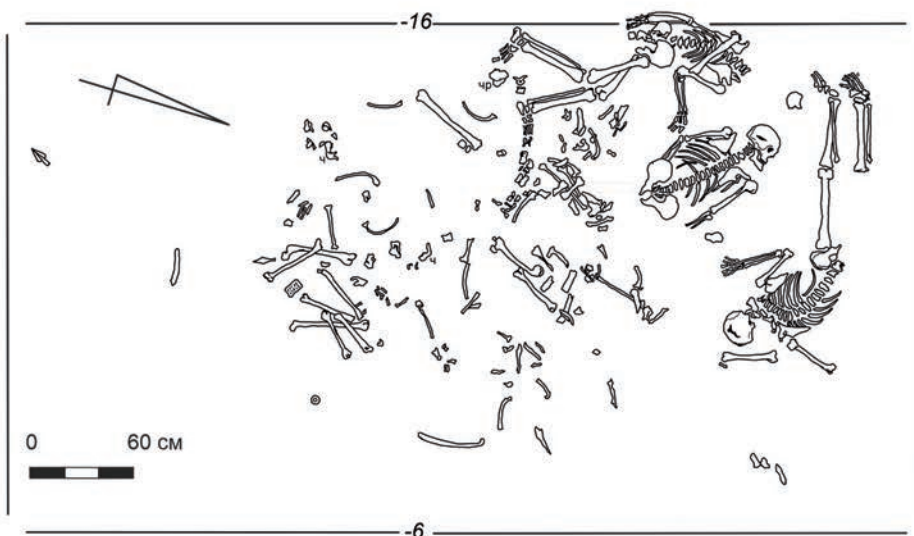

Fig. 7. Korkino I settlement. Human remains near dwelling 3, after – Chemyakin 2015: fig. 3
7-сур. Коркино I қонысы. 3 тұрғын үйге жақын адам қаңқалары ([Чемьякин 2015: рис. 3] бойынша)
Рис. 7. Поселение Коркино I. Человеческие останки близ жилища 3 (по: [Чемьякин 2015: рис. 3])



Interments are quite various from the point of view of age and gender. Some of the dead (presumably small children and some of the adults) were buried according to the usual tradition – in a contracted position, on the left side, and accompanied by pottery (Rodnikovoe settlement [Kupzova, Faisullin 2012], Ustye [Vinogradov et al. 2013: 111–112], Lis’yi Gory [Petrov, Kupriyanova 2016] (fig. 6).

Other skeletons (or parts of skeletons), usually adults, had indications of special treatment of their bones – burning, dismemberment, interment of only part of the corpse, or they were in a non-standard position (Tanalyk I [Garustovich, Kotov 2007], Kuzminkovskoe II settlement, Korkino (fig. 7), Pokrovskoe settlement, Tokskoe settlement, adult burial at Ustye [Porokhova 1989, 62; Morgunova et al. 2001; Faisullin 2012; Vinogradov et al. 2013], Mirnyi IV [Chemyakin 2015], Lisakovskoe [Usmanova 2005]. Separate human bones were found in the cultural soil and in the fill of dwellings at the settlement of Gornyi [Antipina 2004: 239].

Unfortunately, anthropological identification was conducted only for Gornyi, Muradymovo, Tokskoe, Lis’yi Gory settlements as well as Tanalyk, Ustye and Korkino.

At the Tokskoe settlement according to A. Chochlov, the bones of about 10 individuals were found. All of these individuals were adults except for one teenager 12–14 years old. One skeleton belonged to a female age 20–25 years old, and the rest were males, ages 30 to 50 years old [Faizullin 2012: 228].

A paired burial was found at Muradymovo, which included a rather elderly male and female couple (40–45 years old). They were buried on the left side and in a standard position above the wall of the settlement. Children (8 months and a one year old) were buried in the standard position and accompanied with Srubnaya pottery in the dwelling and in the fill of the wall [Obydenova et al. 2002: 78].

At the Tanalyk settlement at least three adult burials were found, one was a female. The corpses were buried without the standard mortuary treatment and the skeletons were incomplete [Garustovich, Kotov 2007: 35]. At Gornyi, the bones of two newborns, an adolescent, and an adult female and male were found [Antipina 2004: 239]. At Korkino and Mirnyi, the remains of adult males killed as a result of a war conflict were discovered [Chemyakin 2015].

In opposition to the above-mentioned burials, the grave at the Lis’yi Gory settlement seemed to be particularly touching [Petrov, Kupriyanova 2016]. During the excavation, a burial of a female about 30 years old with two newborn babies (twins?) was discovered near the stone menhir near the border of the settlement. The burial was arranged according to the normal Srubnaya rite with the children’s bodies placed in front of the face of the dead woman.

Interpretation

Many interpretations of intramural burials have been proposed on the basis of historic and ethnographic sources [Antonova 1990: 86; Scott 1999: 99–102; Beilke-Voigt 2008: 26; Mishina 2010: 140; Karl, Löcker 2011, etc.]. The search for explanations follows two main trends. One version is based on the idea of a construction sacrifice. Alternative versions proceed from the assumption that the children died from natural causes and were buried inside houses for religious or practical reasons, depending on the context. These interpretations have recently gained popularity. While infanticide has been reliably documented by both written and oral sources, demonstrating it archaeologically is very difficult. This is why hypotheses based on ideas such as the magic revival of deceased newborns in the same family or maintaining women’s fertility are more popular [Scott 1999: 105–107; Beilke-Voigt 2008]. Explanations relating to ancestor



and fertility worship are relatively common [Bibikov 1953: 197–198; Scott 1999: 102]. Specialists in the Mesolithic and Neolithic of the Balkans believe that the custom of intramural burials was aimed at preserving the “reproductive capacity” of the dwelling as the place where members of a family or of a lineage lived [Boric, Stefanovic 2004: 541], implying that fecundity was in some way associated with place of residence. Nowhere is the connection between birth and death inherent in the fertility cult so manifest as in the death and burial of a newborn child. Returning to burials found in Bronze Age dwellings (Sintashta and Petrovka), the idea of construction sacrifice must be rejected. Nothing whatever indicates infanticide. There are likewise no unambiguous indications that burials were made during construction. Only one thing is evident: people continued to live in their dwellings after they had buried the children under the floors. Evidence for this is burial 8 at Ustye I covered by the floor coating and reopened to accommodate a second burial. Child burials were not found in every dwelling. Their context demonstrates the special care on behalf of the adults: the bodies were placed in the graves in a standard position, accompanied by vessels, and in one case, an animal was sacrificed. Most children’s graves are situated near the corners and walls of the construction pit or near the entrances to structures or passages connecting separate compartments, but not where people were most likely to tread. The same tendency has been observed at chronologically and geographically divergent sites [Molodin et al. 2004: 181, 199; Mishina 2010: 141; Kiryushin et al. 2004: 217; Khronologiya... 2005:325]. These places were traditionally regarded as being ritually “cleaner” than others [Beilke-Voigt 2008: 28]. The fact that the age of the child varies and that two individuals, a newborn and a one-year-old infant, were buried in a single grave also runs counter to the idea of infanticide.

Why were children buried within the family space? This was not a universal practice in Bronze Age societies. Unusual practices might be caused by extraordinary situations such as the death of a great number of children, animals, etc. Care for the preservation or restoration of fertility, whether human or that of domestic animals, might play a principal role in burial rites even in cases where the child suffered a violent death. However, in this case too, according to the idea of fertility, attested by animal sacrifices at extramural cemeteries [Zdanovich 2005], the death of an infant could symbolize revival and be used to maintain relations between the living and the dead, between humans and deities. A more prosaic explanation is that burying newborns and very young infants was a family duty and did not require rites such as those practiced during the burial of adults or older children. Certain families might have wished that the child could stay with them, as it were, even after death. The practice of leaving dead infants inside homes has survived until recently [Baiburin 1983; Boric, Stefanovic 2004; Mishina 2010]. Indirect proof of the above is that infant burials at Ural settlements sites have been found in far from all houses. Our last point is that a modest sample notwithstanding, the evidence is suggestive and relevant to understanding the origins of the Bronze Age societies and their ideologies. We call on our colleagues to publish all instances of this practice, unusual for the Urals and Western Siberia.

Adult burials cannot be interpreted in a generalized manner. In Russian scientific literature, burials at settlements are still considered, in general and interpreted as, “sacrifices” without firm reasons. Nevertheless, it seems clear now that we have remains of different activities, which were conducted according to different purposes.

The burials of the first type (according to the normative ritual) could have been dug if there was no opportunity or time to bury the dead in the formal cemetery (abandonment of the living settlement, runaway



to another place and so on), or as a sign of special treatment possibly related to sentimental aspects such as the grave of the female with the newborns in the periphery of the Lis'yi Gory settlement. Little children have often been buried in the domestic space during the whole of human history.

The burials of the second type may have been the result of some kind of conflict, crime, or legitimized violence (sacrifice, execution). Is it possible that some dwellings or other parts of the settlement were not inhabited at that time? Perhaps the settlement was destroyed as a result of war-like conflict and nobody survived to bury the dead.

Unfortunately, sometimes the poor quality of excavation and publication does not allow us to interpret the context decisively.

As regards the third type – non-articulated bones, which were found in the cultural soil or in the fill of dwellings – it is hard to say for what reasons or activities they were used. Non-articulated bones could have been used for various purposes during the rituals. Bones of newborns may have been from destroyed children's burials. Nevertheless, most of the ancient settlements usually have some human bones in their osteological collections.

Conclusion

As a result, in order to interpret the settlement burials in the Ural Bronze Age, we need to be aware that these burials are varied and therefore could be determined to have had different circumstances. We can divide the burials into three types. The first type of grave is arranged along the common burial rules of the society. There are children's burials as well as the adult graves. The second type of burial does not fit the common norms. They are disarticulated, mutilated bodies in a non-standard position. All of these burials belonged to adults, mostly to males. The third type of burial consists of finds of separate bones or parts of a skeleton. They belonged to both adults and children. Thus, we may conclude that in the early Abashevo-Sintashta period, children's burials at the settlements were a variant of the normal burial practice. Adult burials were rather deviant. In the next Srubnaya-Andronovo period, both children and adult burials at the settlements were allowed the normal burial practice. However, a significant number of the adult burials were "deviant". We can, therefore, see that the deviant burials were related to adult individuals in both periods.

Acknowledgements. My special gratitude goes to Dr. Karlene Jones-Bley (University of California, Los Angeles) for her help with my English and kind attention to my work.

ӘДЕБИЕТ

- 1 Антипина Е.Е. Археозоологические материалы // Каргалы, т. III: Селище Горный: Археологические материалы: технология горно-металлургического производства: Археобиологические исследования / Сост. и науч. ред. Е.Н. Черных. М.: Языки славянской культуры, 2004. С. 182–239.
- 2 Антонова Е.В. Обряды и верования первобытных земледельцев Востока. М.: Наука, 1990. 287 с.
- 3 Байбурун А.К. Жилище в обрядах и представлениях восточных славян. Л.: Наука, 1983. 192 с.
- 4 Бибииков С.Н. Поселение Лука Врублевская. М.; Л.: изд-во АН СССР, 1953. 460 с. (МИА. № 38).
- 5 Виноградов Н.Б. Кулевчи III – памятник петровского типа в Южном Зауралье // КСИА. 1982. № 169. С. 94–99.
- 6 Гарустович Г.Н., Котов В.Г. Таналькское I поселение // Уфимский археологический вестник. 2007. № 6–7. С. 32–49.
- 7 Древнее Устье: укрепленное поселение бронзового века в Южном Зауралье / Отв. ред. Н.Б. Виноградов. Челябинск: АБРИС, 2013. 482 с.



- 8 *Епимахов А.В.* Бронзовый век Южного Урала (экономический и социальный аспекты): автореф. дис. ... докт. ист. наук. Екатеринбург, 2010. 55 с.
- 9 *Зданович Г.Б., Малютина Т.С., Зданович Д.Г.* Аркаим. Археология укрепленных поселений. Кн. 1. Жилища и жилое пространство. Челябинск: Изд-во Челяб. гос. ун-та, 2020. 450 с.
- 10 *Зданович Д.Г.* Жертвоприношения животных в погребальном обряде населения степного Зауралья эпохи средней бронзы: автореф. дис. ... канд. ист. наук. Екатеринбург, 2005. 23 с.
- 11 *Кирчо Л.Б., Алекшин В.А.* Хронология эпохи позднего энеолита – средней бронзы Средней Азии (погребения Алтын-депе) (сер. Труды ИИМК РАН. Т. XVI). СПб.: Нестор-История, 2005. 540 с.
- 12 *Кирюшин Ю.Ф., Малолетко А.М., Тишкин А.А.* Березовая Лука – поселение эпохи бронзы в Алейской степи. Т. 1. Барнаул: Изд-во Алтайского ун-та, 2004. 288 с.
- 13 *Куприянова Е.В.* Альтернативные погребальные практики: погребения людей на поселениях бронзового века // *Степная Евразия в эпоху бронзы: культуры, идеи, технологии.* Сб. науч. тр. к 80-летию Геннадия Борисовича Здановича / Отв. ред. Д.Г. Зданович. Челябинск: Изд-во Челяб. гос. ун-та, 2018. С. 184–197.
- 14 *Купцова Л.В., Файзуллин И.А.* Родниковое поселение позднего бронзового века в Западном Оренбуржье // *Археологические памятники Оренбуржья* / Отв. ред. Н.Л. Моргунова. Вып. 10. Оренбург: Изд-во ОГПУ, 2012. С. 70–100.
- 15 *Мишина Т.Н.* Социальный аспект изучения интрамуральных детских погребений (по материалам эпохи ранней бронзы телля Юнаците, Балканы) // *КСИА.* 2010. № 224. С. 136–149.
- 16 *Молодин В.И., Епимахов А.В., Марченко Ж.В.* Радиоуглеродная хронология эпохи бронзы Урала и юга Западной Сибири: принципы и подходы, достижения и проблемы // *Вестник НГУ. Сер.: История, филология.* 2014. Т. 13. № 3: Археология и этнография. С. 136–167.
- 17 *Молодин В.И., Парцингер Г., Гаркуша Ю.Н., Шнеевайс Й, ..., Кулин Н.А.* Чича – городище переходного от бронзы к железу времени в Барабинской лесостепи. Новосибирск: ИАЭТ СО РАН, 2004. Т. 2. 336 с.
- 18 *Моргунова Н.Л., Халяпин М.В., Халяпина О.А.* ПКузьминковское поселение эпохи бронзы // *Археологические памятники Оренбуржья* / Отв. ред. Н.Л. Моргунова. Вып. 5. Оренбург: Изд-во ОГПУ, 2001. С. 99–125.
- 19 *Моргунова Н.Л., Евгеньев А.А., Купцова Л.В.* Погребальный комплекс синташтинского времени на поселении Малоюлдашево I в Западном Оренбуржье // *Археология, этнография и антропология Евразии.* 2015. № 2. С. 64–71.
- 20 *Обыденнова Г.Т., Шутелева И.А., Щербаков Н.Б.* Место Мурадымовского поселения в системе памятников бронзового века Башкирского Приуралья // *Степи Евразии в древности и средневековье.* М-лы междунар. науч. конф., посвящ. 100-летию со дня рождения М.П. Грязнова (г. Санкт-Петербург, март 2002 г.). В 2-х кн. / Отв. ред. Ю.Ю. Пиотровский. Кн. I. СПб.: Гос. Эрмитаж, 2002. С. 205–206.
- 21 *Петров Ф.Н., Куприянова Е.В.* Поселения эпохи бронзы в Аркаимской долине: по результатам разведочных исследований 1997–2015 гг. М.: Московский областной общественный фонд «Наследие», 2016. 148 с.
- 22 *Порохова О.И.* Срубно-алакульское Покровское поселение в Западном Оренбуржье // *Материалы по эпохе бронзы и раннего железа Южного Приуралья и Нижнего Поволжья* / Отв. ред. Ю.А. Морозов, А.Х. Пшеничнюк. Уфа: БНЦ УрО АН СССР, 1989. С. 60–71.
- 23 *Сальников К.В.* Абашевская культура на Южном Урале // *СА.* 1954. № XXI. С. 52–94.
- 24 *Сальников К.В.* Очерки древней истории Южного Урала. М.: Наука, 1967. 408 с.
- 25 *Ткачев А.А.* Особенности нуртайских комплексов Центрального Казахстана // *Вестник археологии, антропологии и этнографии.* 1999. № 2. С. 2–29.
- 26 *Усманова Э.Р.* Могильник Лисаковский I: факты и параллели. Караганда; Лисаковск: Караганд. гос. ун-т им. Е.А. Букетова, 2005. 232 с.
- 27 *Файзуллин И.А.* Погребения на поселениях эпохи бронзы на территории Западного Оренбуржья // *Известия Самарского научного центра РАН.* 2012. Т. 14. № 3. С. 226–230.
- 28 *Чемякин Ю.П.* Следы военных конфликтов на алакульских поселениях // *Этнические взаимодействия на Южном Урале: м-лы VI Всерос. науч. конф. (г. Челябинск, 28 сентября – 2 октября 2015)* / Отв. ред. А.Д. Таиров. Челябинск: Челяб. гос. краеведч. музей, 2015. С. 169–176.



- 29 Aspöck E. What Actually is a ‘Deviant Burial’? Comparing German-Language and Anglophone Research on ‘Deviant Burials’ // *Deviant Burial in the Archaeological Record* / Ed. E.M. Murphy. Oxford: Oxbow Books, 2008. Pp. 17–34.
- 30 Beilke-Voigt I. Burials of children in houses and settlements during the Roman Iron Age and Early Medieval Period in Northern Germany and Denmark // *Children, Identity and the Past* / Eds.: L.H. Dommasnes and M. Wigglesworth. Cambridge: Cambridge University Press, 2008. Pp. 16–35
- 31 Boric D. and Stefanovic S. Birth and death: Infant burials from Vlasac and Lepenski Vir // *Antiquity*. 2004. № 78 (301). Pp. 526–546.
- 32 Karl R., Löcker K. Thrown Out with the Bathwater or Properly Buried? Neonate and infant skeletons in a settlement context on the Durnberg bei Hallein, Austria // *(Re)Thinking the Little Ancestor: New Perspectives on the Archaeology of Infancy and Childhood* / Eds.: M. Lally and A. Moore. Oxford: BAR International Series, 2011. Pp. 37–46.
- 33 Koryakova L.N., Epimakhov A.V. The Urals and Western Siberia in the Bronze and Iron Age. Cambridge: Cambridge University Press, 2007. 374 p.
- 34 Koryakova L.N., Krause R., Epimakhov A.V., Sharapova S.V., Panteleyeva S.E., Berseneva N.A., Fornasier J., Kaiser E., Molchanov I.V., Chechushkov I.V. Archaeological studies of the Kamenny Ambar (Olgino) fortified settlement // *Archaeology, Ethnology & Anthropology of Eurasia*. 2011. No. 4 (39). Pp. 61–74.
- 35 Scott E. The Archaeology of Infancy and Infant Death. Oxford: BAR International Series, 1999. 136 p.
- 36 Vinogradov N.B., Berseneva N.A. Intramural Burials of Children at Bronze Age Sites in the Southern Urals (early 2nd millennium BC) // *Archaeology, Ethnology & Anthropology of Eurasia*. 2013. No. 41 (3). Pp. 59–67.

REFERENCES

- 1 Antipina, E. E. 2004. In: Chernykh, E. N. (ed.) *Selishie Gornyi: Arkheologicheskie materialy: tekhnologiya gorno-metallurgicheskogo proizvodstva: Arkheobiologicheskie issledovaniya (Gorny Settlement: Archaeological materials: technology of mining and metallurgical production: Archaeobiological research)*. Vol. III. Moscow: “Yasyki slavyanskoy kultury” Publ., 182–239 (in Russian).
- 2 Antonova, E. V. 1990. *Obryady i verovaniya pervobytnykh zemledeltsev Vostoka (Rituals and beliefs of primitive farmers of the East)*. Moscow: “Nauka” Publ. (in Russian).
- 3 Baiburin, A. K. 1983. *Zhilische v obryadakh i predstavleniyakh vostochnykh slavyan (Dwelling in the rituals and beliefs of the Eastern Slavs)*. Leningrad: “Nauka” Publ. (in Russian).
- 4 Bibikov, S. N. 1953. *Poselenie Luka Brublevetskaya (Luka Brublevetskaya settlement). Materialy i issledovaniya po arkheologii SSSR (Materials and Research on the Archaeology of the USSR)*, 38. Moscow, Leningrad: USSR Academy of sciences (in Russian).
- 5 Vinogradov, N. B. 1982. In: *Kratkiye soobshcheniya Instituta arkheologii (Brief Communications of the Institute of Archaeology)*, 169, 94–99 (in Russian).
- 6 Garustovich, G. N., Kotov, V. G. 2007. In: *Ufimskiy arkheologicheskii vestnik (Ufa Archaeological Herald)*, 6–7, 32–49 (in Russian).
- 7 Vinogradov, N. B. (ed.). 2013. *Drevnee Ust’ye: Ukrepennoe Poselenie Bronzovogo Veka v Yuzhnom Zaural’ye (Ancient Ustye: a fortified Bronze Age settlement in the Southern Trans-Urals)*. Chelyabinsk: “ABRIS” Publ. (in Russian).
- 8 Epimakhov, A. V. 2010. *Bronzovyi vek Yuzhnogo Urala (ehkonomicheskij i socialnyi aspekty) (Bronze Age of the Southern Urals (economic and social aspects))*. Abstract of the thesis Doctor of historical sciences. Yekaterinburg: Institute of History and Archaeology (in Russian).
- 9 Zdanovich, G. B., Malyutina, T. S., Zdanovich, D. G. 2020. *Arkaim. Arkheologiya ukrepionnykh poseleniy. Kn. 1. Zhilishcha i zhiloe prostranstvo (Archaeology of fortified settlements. Book 1. Dwellings and living space)*. Chelyabinsk: Chelyabinsk University Press (in Russian).
- 10 Zdanovich, D. G. 2005. *Zhertvoprinosheniya zhitovnykh v pogrebalnom obryade naseleniya stepnogo Zauralya epokhi srednei bronzy (Animal sacrifices in the funeral rites of the population of the steppe Trans-Urals of the*



- Middle Bronze Age*). Abstract of the thesis Candidate of historical sciences. Yekaterinburg: Institute of History and Archaeology (in Russian).
- 11 Kircho, L. B., Alekshin, V. A. 2005. *Khronologiya epokhi pozdnego eneolita – sredney bronzy Sredney Azii (pogrebeniya Altyn-depe) Chronology of the Late Eneolithic – Middle Bronze Age of Central Asia (burials of Altyn-Depe)*. *Trudy Instituta istorii materialnoy kultury RAN (Proceedings of the Institute for the History of Material Culture of RAS)*, XVI. Saint Petersburg: “Nestor-Istoriya” Publ. (in Russian).
- 12 Kiryushin, Yu. F., Maloletko, A. M., Tishkin, A. A. 2004. *Berezovaya Luka – poseleniye epokhi bronzy v Aleyskoi stepi (Berezovaya Luka is a Bronze Age settlement in the Alei steppe)*. Vol. 1. Barnaul: Altay State University Press (in Russian).
- 13 Kupriyanova, E. V. 2018. In: Zdanovich, D. G. (ed.) *Stepnaya Evrasia v epokhy bronzy: kultury, idei, tekhnologii (Steppe Eurasia in the Bronze Age: cultures, ideas, technologies)*. Chelyabinsk: Chelyabinsk University, 184–197 (in Russian).
- 14 Kuptsova, L. V., Faizullin, I. A. 2012. In: Morgunova, N. L. (ed.) *Arkheologicheskie pamyatniki Orenburzh'ya (Orenburg Archaeological Sites)*, 10, 70–100 (in Russian).
- 15 Mishina, T. N. 2010. In: *Kratkiye soobshcheniya Instituta arkheologii (Brief Communications of the Institute of Archaeology)*, 224, 136–149 (in Russian).
- 16 Molodin, V. I., Epimakhov, A. V., Marchenko, Zh. V. 2014. In: *Vestnik Novosibirskogo gosudarstvennogo universiteta (Herald of Novosibirsk State University)*, 13 (3), 136–167 (in Russian).
- 17 Molodin, V. I., Parzinger, H., Garkusha, Yu. N., Schneeveiß, J., ..., Kulin N. A. 2004. *Chicha – gorodishche perekhodnogo ot bronzy k zhelezu vremeni v Barabinskoy lesostepi (Chicha – a settlement of the transitional period from Bronze to Iron Age in the Barabinsk forest-steppe)*. Vol. 2. Novosibirsk: Institute of Archaeology and Ethnography of the RAS (in Russian).
- 18 Morgunova, N. L., Khalyapin, M. V., Khalyapina, O. A. 2011. In: Morgunova, N. L. (ed.) *Arkheologicheskie pamyatniki Orenburzhiya (Orenburg Archaeological Sites)* 5, 99–125. (in Russian).
- 19 Morgunova, N. L., Evgen'ev, A. A., Kupzova, L. V. 2015. In: *Arkheologiya, etnografiya i antropologiya Evrazii (Archaeology, Ethnology & Anthropology of Eurasia)*, 2, 64–71 (in Russian).
- 20 Obydenova, G. T., Shuteleva, I. A., Scherbakov, N. B. 2002. In: Piotrovskiy, Yu. Yu. (ed.) *Stepi Evrazii v drevnosti i srednevekoye (Steppes of Eurasia in ancient times and the Middle Ages)*, 1. Saint Petersburg: State Hermitage, 205–206 (in Russian).
- 21 Petrov, F. N., Kupriyanova, E. V. 2016. *Poseleniya epokhi bronzy v Arkaimskoi doline: po rezultatam razvedochnykh issledovaniy 1997–2015 gg. (Bronze Age settlements in the Arkaim Valley: based on the results of scientific studies in 1997–2015)*. Moscow: “Nasledie” Publ. (in Russian).
- 22 Porokhova, O. I. 1989. In: Morozov, Yu. A., Pshenichnyuk, A. Kh. (eds.) *Materialy po epokhe bronzy i rannego zhelesa Yuzhnogo Priuraliya i Nizhnego Povolzh'ya (Materials on the Bronze Age and Early Iron Age of the Southern Urals and Lower Volga region)*. Ufa: Bashkir Scientific Center of the Academy of sciences of the USSR, 60–71 (in Russian).
- 23 Salnikov, K. V. 1954. In: *Sovetskaya arkheologia (Soviet Archaeology)*, XXI, 52–94 (in Russian).
- 24 Salnikov, K. V. 1967. *Ocherki Drevney istorii Yuzhnogo Urala (Essays on the ancient history of the Southern Urals)*. Moscow: “Nauka” Publ. (in Russian).
- 25 Tkachev, A. A. 1999. In: *Vestnik arkheologii, antropologii i etnografii*, 2, 2–29 (in Russian).
- 26 Usmanova, E. R. 2005. *Mogilnik Lisakovskiy I: Fakty i Paralleli (Cemetery Lisakovsky I: facts and parallels)*. Karaganda; Lisakovsk (in Russian).
- 27 Faizullin, I. A. 2012. In: *Izvestiya Samarskogo nauchnogo tchentra RAN (News of the Samara Scientific Center of the RAS)*, 14 (3), 226–230 (in Russian).
- 28 Chemyakin, Yu. P. 2015. In: Tairov, A. D. (ed.) *Etnicheskie vzaimodeistviya na Yuzhnom Urale (Ethnic interactions in the Southern Urals)*, 169–176. Chelyabinsk: Chelyabinsk State Museum (in Russian).
- 29 Aspöck, E. 2008. In: Murphy, E. M. (ed.) *Deviant Burial in the Archaeological Record*. Oxford: Oxbow Books, 17–34 (in English).



- 30 Beilke-Voigt, I. 2008. In: Dommasnes, L. H., Wrigglesworth, M. (eds.). *Children, Identity and the Past*. Cambridge: Cambridge University Press, 16–35 (in English).
- 31 Boric, D., Stefanovic, S. 2004. In: *Antiquity*, 78 (301), 526–546 (in English).
- 32 Karl, R., Löcker, K. 2011. In: Lally, M., Moore, A. (eds.) *(Re)Thinking the Little Ancestor: New Perspectives on the Archaeology of Infancy and Childhood*. Oxford: BAR International Series, 37–46 (in English).
- 33 Koryakova, L. N., Epimakhov, A. V. 2007. *The Urals and Western Siberia in the Bronze and Iron Age*. Cambridge: Cambridge University Press (in English).
- 34 Koryakova, L. N., Krause, R., Epimakhov, A. V., Sharapova, S. V., Panteleyeva, S. E., Berseneva, N. A., Fornasier, J., Kaiser, E., Molchanov, I. V., Chechushkov, I. V. 2011. In: *Arkheologiya, etnografiya i antropologiya Evrazii (Archaeology, Ethnology & Anthropology of Eurasia)*, 4 (39), 61–74 (in English).
- 35 Scott, E. 1999. *The Archaeology of Infancy and Infant Death*. Oxford: BAR International Series (in English).
- 36 Vinogradov, N. B., Berseneva, N. A. 2013. In: *Arkheologiya, etnografiya i antropologiya Evrazii (Archaeology, Ethnology & Anthropology of Eurasia)*, 41 (3), 59–67 (in English).

Мүдделер қақтығысы туралы ақпаратты ашу. Автор мүдделер қақтығысының жоқтығын мәлімдейді. /
Раскрытие информации о конфликте интересов. Автор заявляет об отсутствии конфликта интересов. /
Disclosure of conflict of interest information. The author claims no conflict of interest.
Мақала туралы ақпарат / Информация о статье / Information about the article.
Редакцияға түсті / Поступила в редакцию / Entered the editorial office: 04.06.2023.
Рецензенттер мақұлдаған / Одобрено рецензентами / Approved by reviewers: 08.08.2023.
Жариялауға қабылданды / Принята к публикации / Accepted for publication: 08.08.2023.

